



DESIGN COLLECTION





熟悉的香氣 從泛黃的木門後輕輕飄來 從 撲面刺眼油煙且悶熱吵雜的 混著汗水的封閉角落 緩緩溢出 和著吱吱作響的煲湯 和著叨叨不斷的斬擊聲 還有 那顆焦慮的 求好心切的 家人般 大廚似的 初心

■ **LISTER 20**

A ergonomic space for conversation.

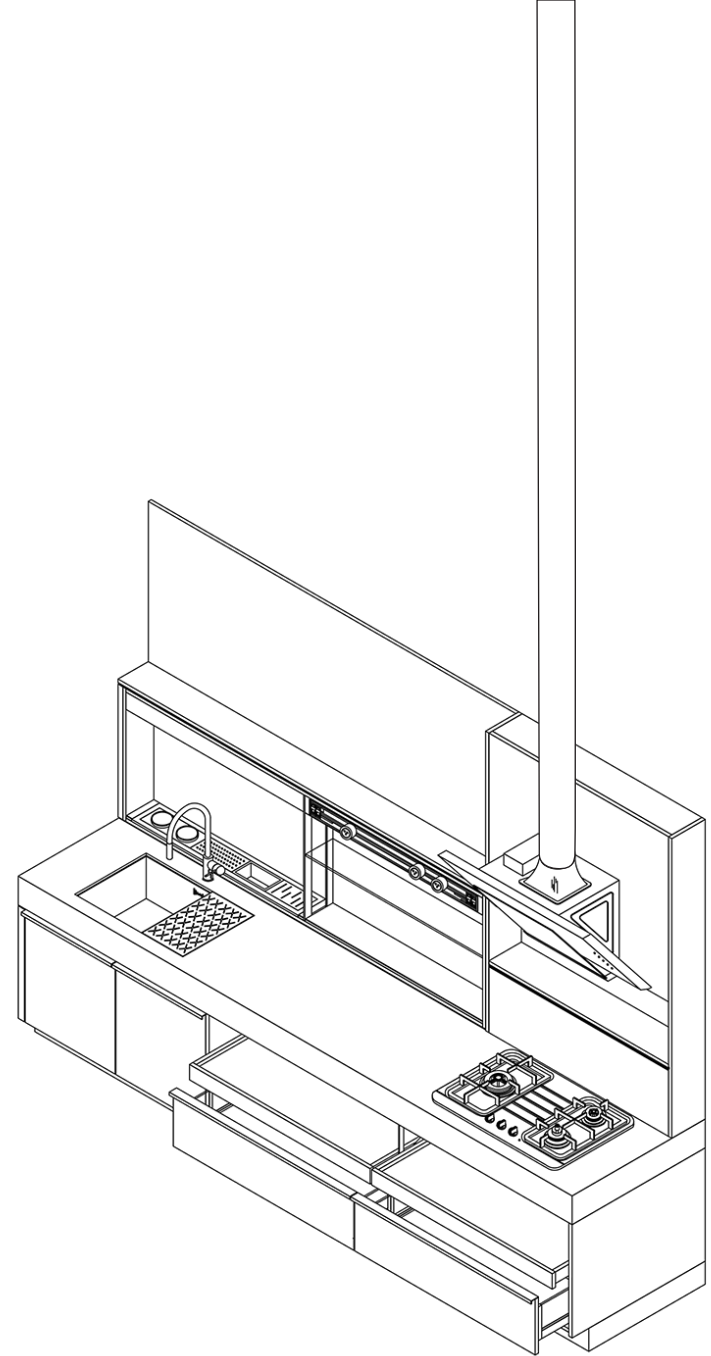



溫潤深邃的可可香氣 伴隨千年沉積縫隙緩緩冒出的 濕熱炊煙 與 滋滋油香 無疆界似 連結拉美大地 所展開的 島嶼烹煮故事





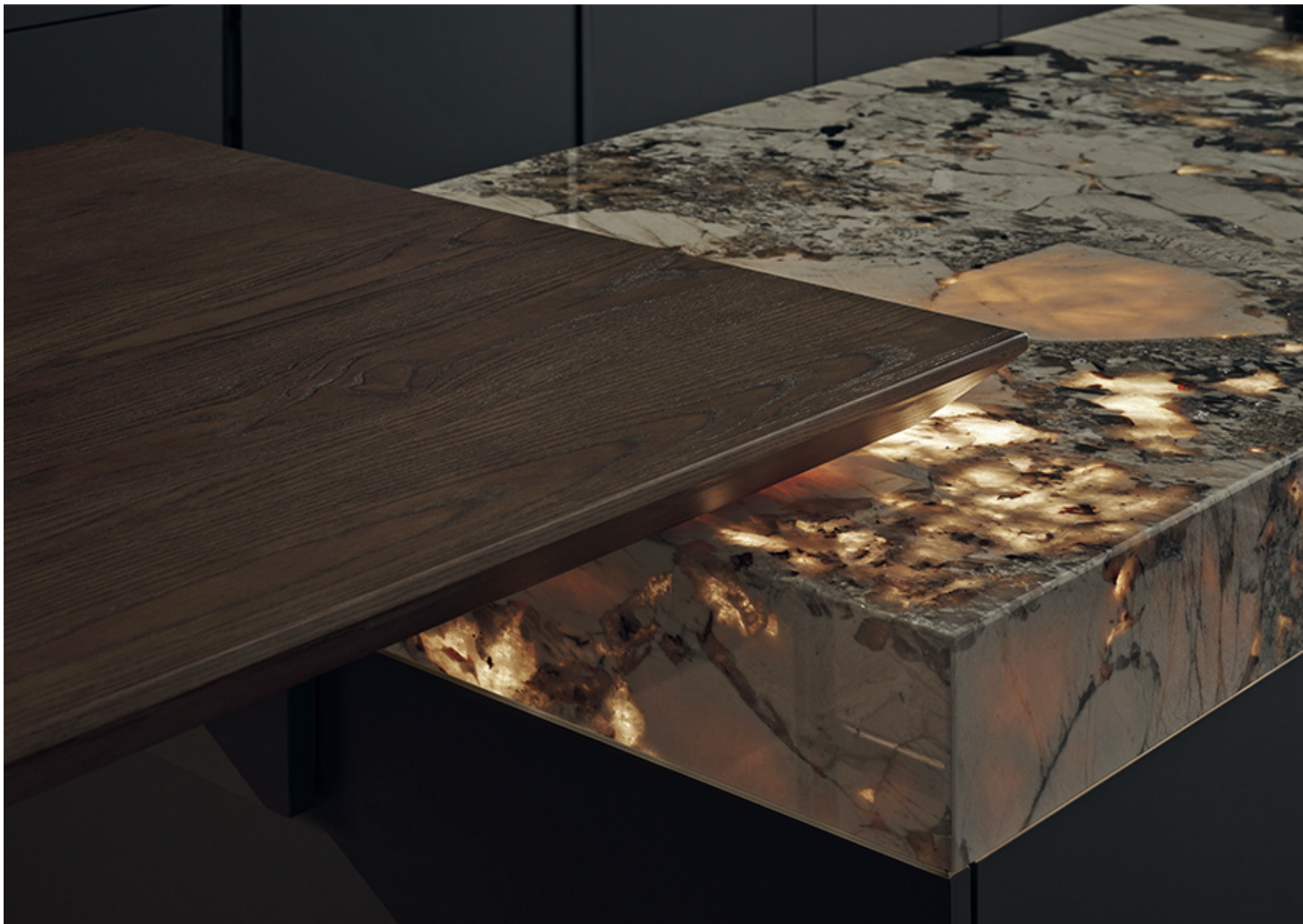

■ KAIA

A place without border.

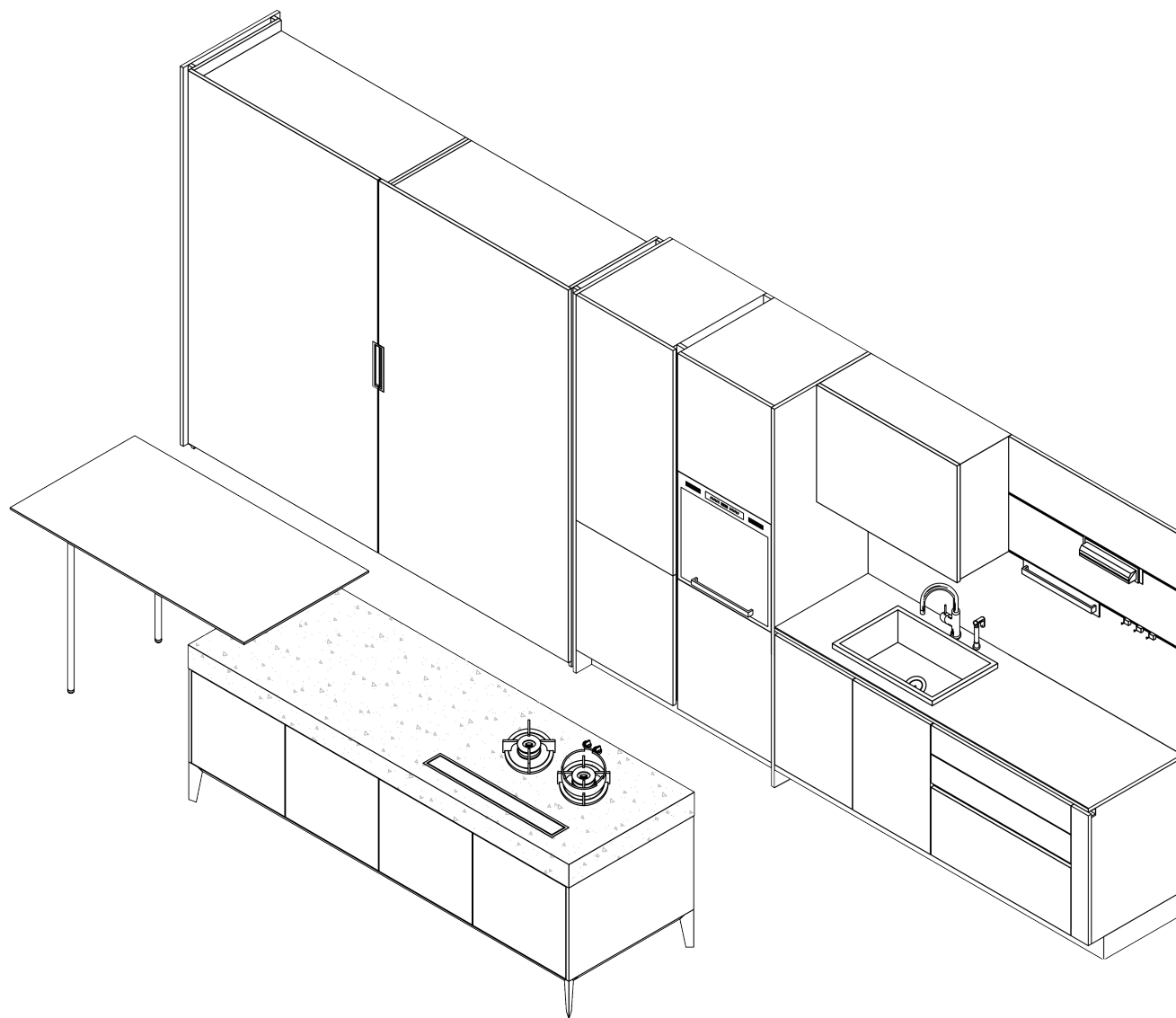



在精密計算的人體工學之下 專注於手中揉捻的麵團 與 鍋中攪拌的羹醬 無需遷就 掌控烹飪自主權



■ CUBE ISLAND

is as individual as you are.

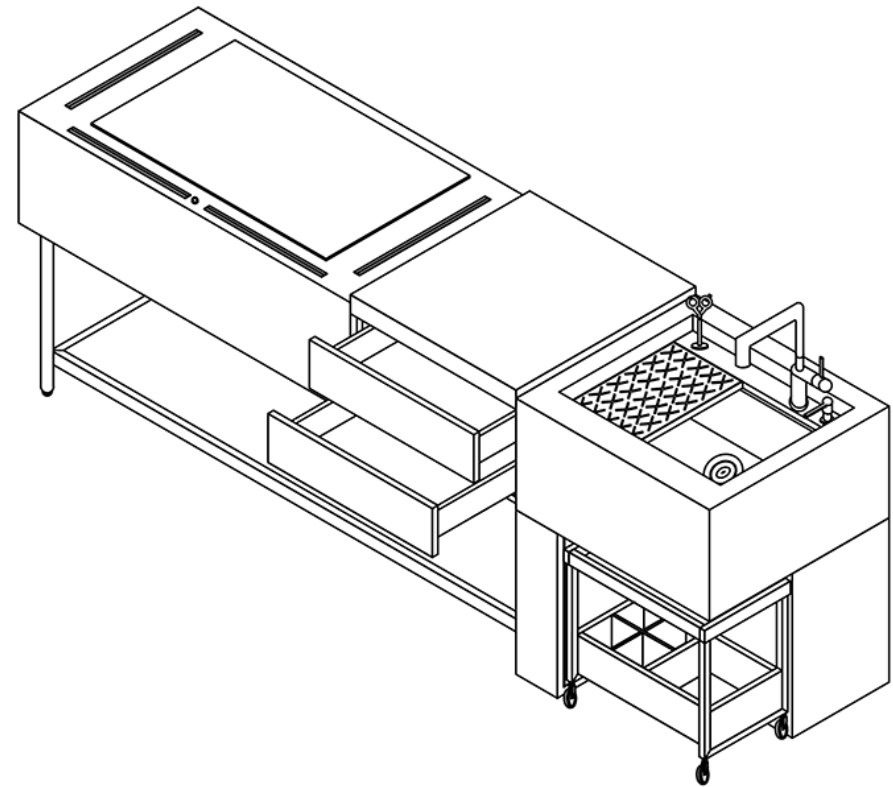









料理的細微之處 始於理性計算 感性拿捏佐以 檯面上唱著歌的巴西里

■ **FORM 15**

Elements
for the entire
kitchen.

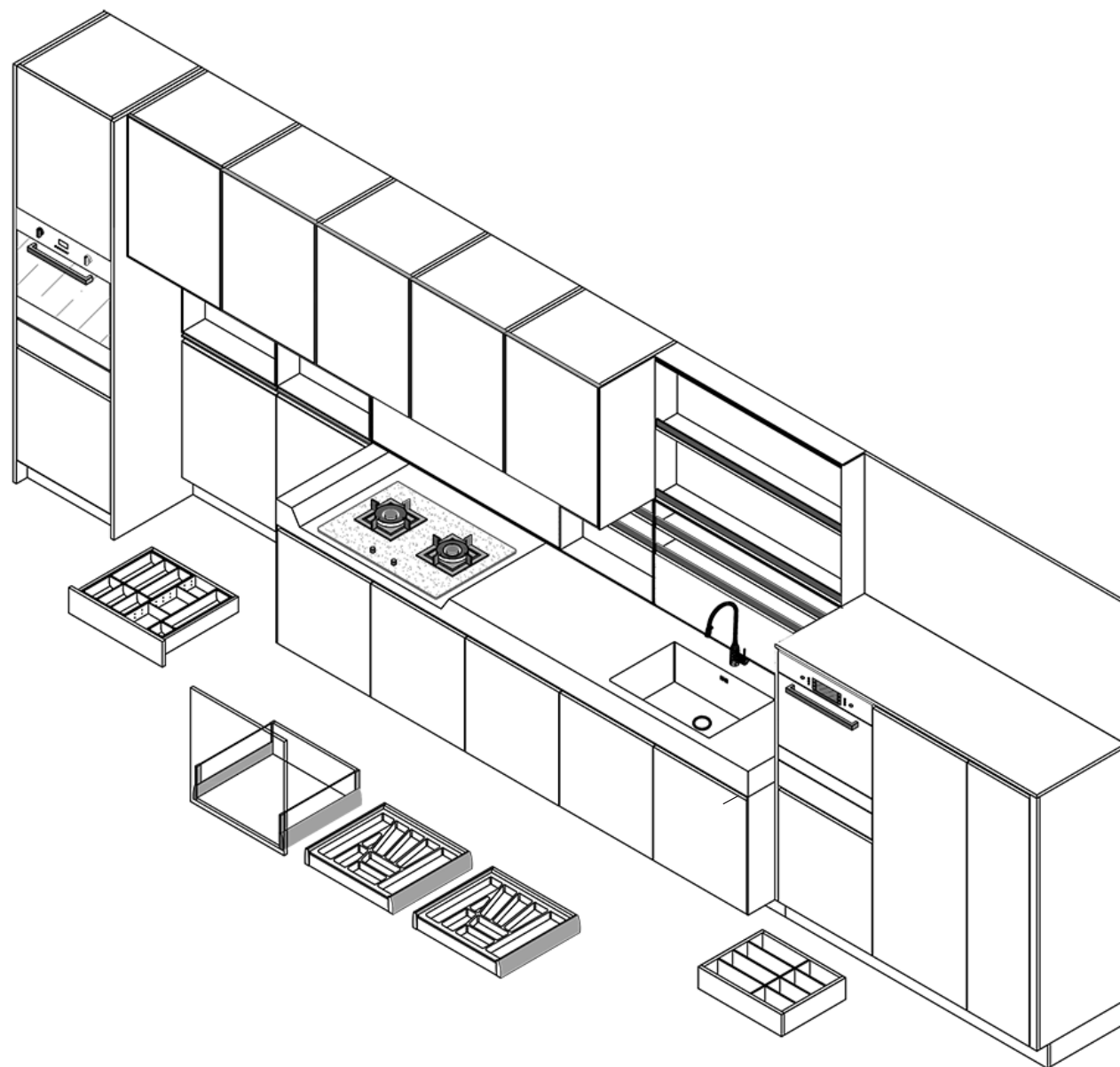



■ **HOLZPRESSO**

An everyday cafe & water unit.

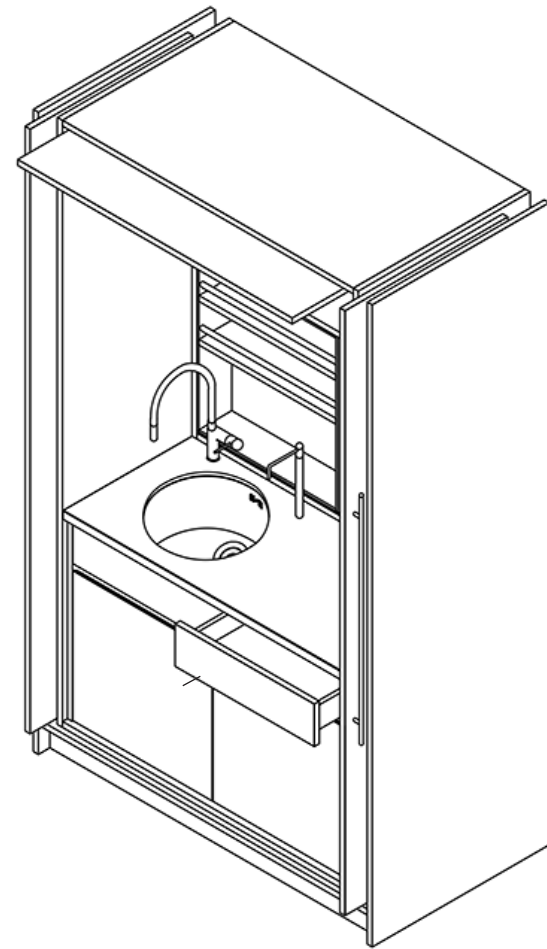





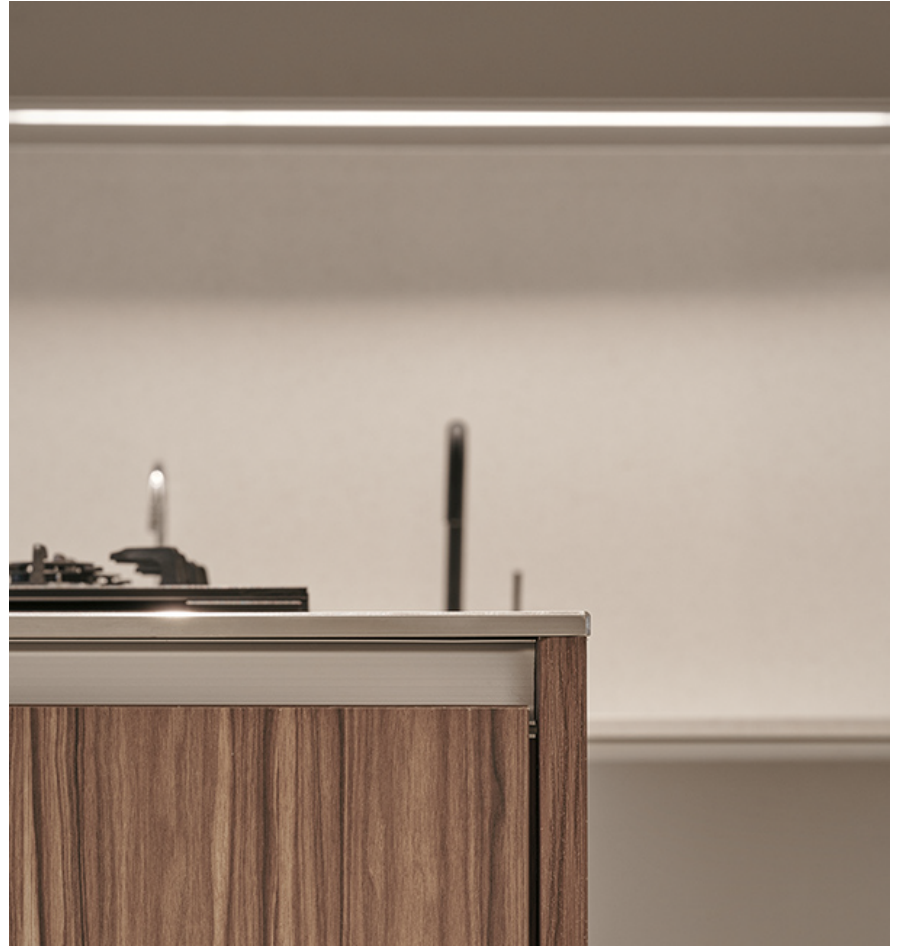

DESIGN FOR SOCIETY



現代廚房自1930年代的德國開始發展，首套一體化的Frankfurter Küche，從原本為了戰後的社會需求，經歷百年的演變，一直到今天的模樣——除了工作以外，更是家人朋友彼此聯絡情感的重要空間。在我多年的廚具設計生涯中，曾經深入了解並設計、銷售多個德國經典奢華廚具品牌，無一不是希望藉由這個空間，強化人與人之間的關係。在接手家族櫥櫃代工廠並創立HOLZ之後，我亦以此為目標，不斷的為台灣廚具美學、人體工學機能、甚至二性平權上，做出與傳統封閉式廚房徹底不同但卻保有濃厚島嶼人情味的烹飪空間。雖然廚房灶腳的存在，並不像是名車或奢侈配件，無法外露炫耀，只能靜靜的安置於室內，但當急促的叩叩切菜聲傳出，與檯面上五顏六色唱著歌似的香料伴隨著陣陣撲鼻熱氣，此時的廚房才真正有了生命，而這也是我最大的成就感。

何志祥

2021年 夏 寫於台北

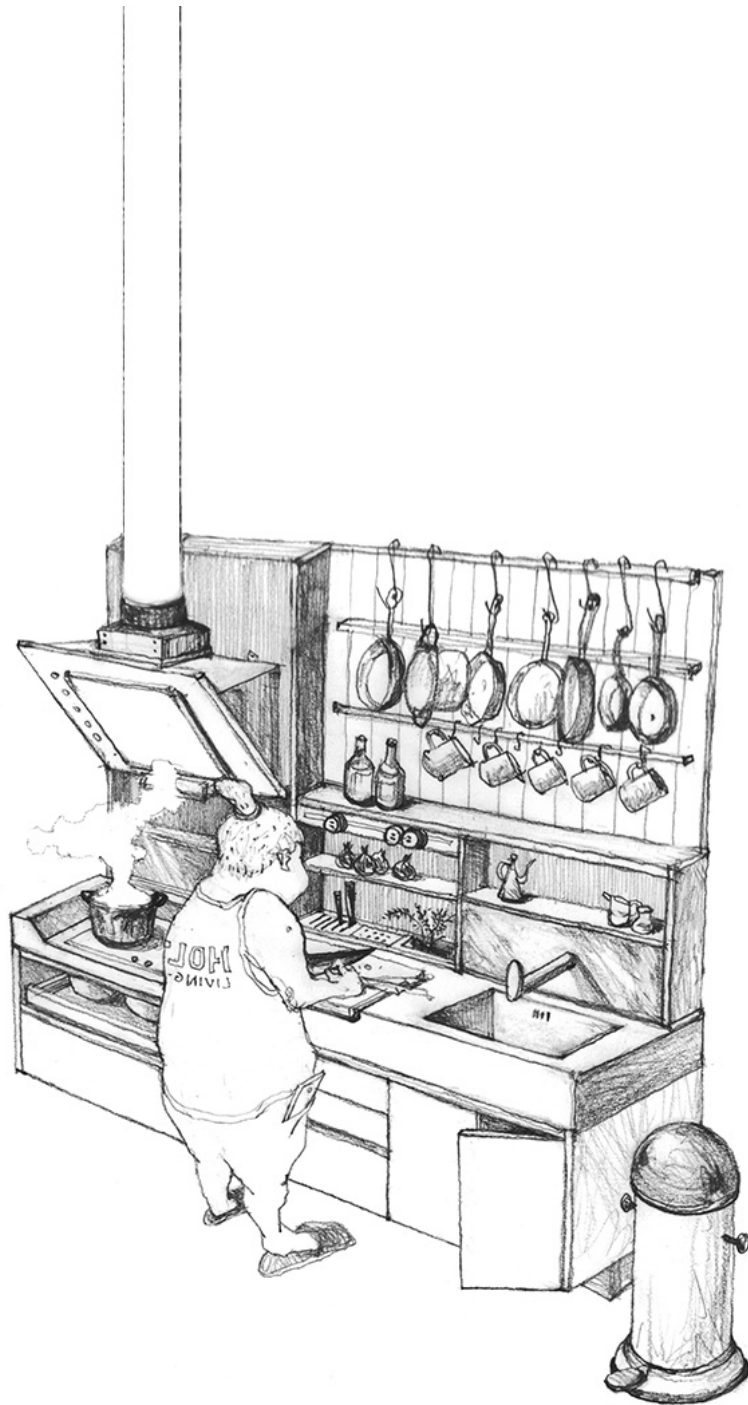



HOLZ

LIVING - KITCHEN

千永陞股份有限公司
HSIANG LIH DECORATION MATERIALS CO.,LTD
No. 3-2, Ln. 150, Sec. 5, Roosevelt Rd.,
Wenshan Dist., Taipei City 116, Taiwan
T+886-2-2932-6165 F+886-2-2932-6330
service@hsiang-lih.com.tw
facebook @ holzkitchen